

240_{VAC}

BULL17 OMI



control unit with built-in inverter and virtual encoder
oil lubricated reductions
personalised release key

**up to 1700 kg**

240 Vac

- Single phase 240 Vac geared motor for intensive use with oil lubricated reductions
- The main control unit, located in the top part of the motor and with integrated inverter, makes it possible to calculate the position of the motor starting from the measurement of current intensity on the electric motor (virtual encoder)
- Oil lubrication guarantees maximum duration of the reducer. The type of oil is very effective and guarantees excellent performance even at low temperatures
- Reduced mechanical wear of components
- The virtual encoder allows proper management of the slowing-down phases, movement tracking (STC system), and torque management in relation to the position of the gate, which guarantees maximum safety
- Adjustable speed from 10 to 24 m/min according to gate weight
- Safety sensor that stops the motor power supply during release operations
- Receiver ONE2.WI is supplied
- Metal release lever

Weight (kg)	Speed (m/min)
1,700	17
1,000	20
500	24



100%
Made in Italy

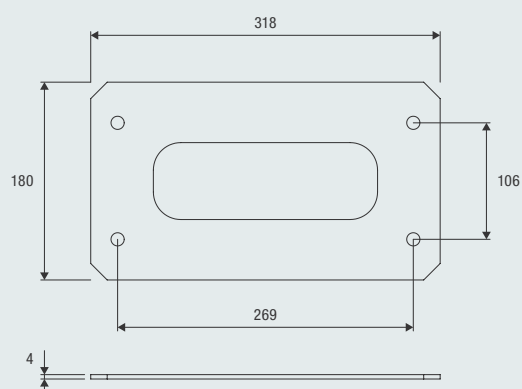
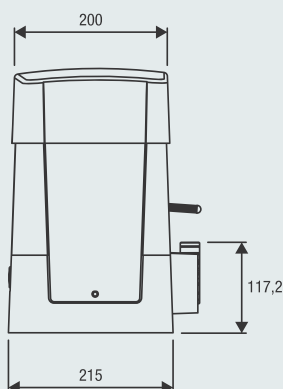
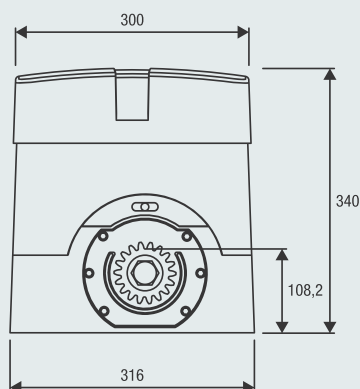

Foundation plate with anchor bolts included.
Motor and floor fixing distance
269 mm x 106 mm, no. 4 Ø 12 mm.

**COMPLETE KITS****KBULL17OMI**

MOTOR

1x **BULL17 OMI**

RACK

8x **RI.M4P** [8 m]

TRANSMITTER

2x **TO.GO4A**

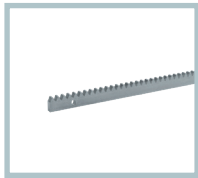

RI.M4F

M4 rack, to weld or attach with screws, 30x12x1000 mm slotted and galvanised. Supplied with M6 metric screws and threaded spacers.
Package of 4 pcs.

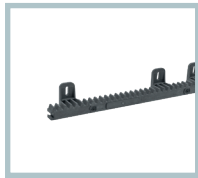

RI.M4P

Nylon rack with steel core, to attach with screws, M4, 28x40x1000 mm. Slotted, provided with self-drilling screws.
Package of 10 pcs.



SB.BULL20.F

Externally fitted anti-intrusion cable unlock device (L=4.5m).



MLS

Magnetic limit switches.



IRI.TX4VA

4-channel transmitter with Advanced Rolling Code and Rolling Code.



IRI.TX4AK

4-channel transmitter with Advanced Rolling Code and Fixed Code.



IRI.LAMP

White full range flashing light, 20-255 Vac with built-in aerial.



IRI.KPAD

Battery operated wireless vandal-proof digital keypad with alert buzzer and backlit buttons. Triple coding: Rolling Code, Programmable Code and Advanced Rolling Code. 254 memorisable codes.



BE.CODE

Wireless battery operated keypad, with triple coding. Numerical membrane keypad to guarantee maximum activation sensitivity. It can memorise up to 254 PINs.



IRI.CELL

Pair of vandal-proof metal covers for PUPILLA/PUPILLA.R photocells, comprising front and rear shells with concealed screw. They can maintain perfect orientation over 180°.



PUPILLA

Pair of photocells adjustable to 180°. Option to synchronise up to 4 pairs, 24 Vac/dc power supply. Easy adjustment through a LED that signals optimal alignment. Compact size: 36x110x35 mm

TECHNICAL DATA	BULL17 OMI
Power supply	240 Vac (50-60Hz)
Motor supply	240 Vac
Max absorbed current	7 A
Max Thrust	1880 N
Max opening speed	24 m/min
Duty cycle	80%*
Protection level	IP44
Operating temperature	-20°C /+50°C
Lubrication	OIL
Max gate weight	1700 kg
Driving gear for rack	M4 Z18
Weight	21.6 kg

* In extreme operating conditions (environment T 50°C, speed 24 m/min, gate weight 500 kg) the cycle falls to 40%



Beninca Australia Pty Ltd
 11/51 Owen St, Glendenning NSW 2761 AUSTRALIA
 P + 61 2 9677 2827
 info@BenincaAustralia.com.au

[licensed installer]